

zibro®

R 17



guarantee

2
YEARS

F	MANUEL D'UTILISATION	2
D	GEBRAUCHSANWEISUNG	14
DK	BRUGSANVISNING	26
E	INSTRUCCIONES DE USO	38
GB	OPERATING INSTRUCTIONS	50
I	ISTRUZIONI D'USO	62
NL	GEbruIKSAANWIJZING	74

Dear Sir, Madam,

Congratulations on your purchase of this Zibro heater, the number one brand amongst portable heaters. You have purchased a first-class quality product, which will serve you for many years to come. This, of course, provided you use the heater correctly. Please read these Directions for Use first, to ensure the maximum lifetime for your Zibro heater.

This appliance comes with a 24-month manufacturer's warranty on all defects in material or workmanship.

We wish you much warmth and comfort from your Zibro heater.

Yours sincerely,

PVG International b.v.

Customer Service Department

1 READ THE DIRECTIONS FOR USE FIRST.

2 IN CASE OF ANY DOUBT, CONTACT YOUR DEALER.

3 BEFORE YOU START READING, FOLD OUT THE LAST PAGE. ▶ ▶ ▶ ▶ ▶ ▶ ▶ ▶ ▶ ▶ ▶ ▶ ▶ ▶

GENERAL DIRECTIONS FOR USE

Below you will find the main steps to be taken for using your heater. For more details, please refer to the MANUAL (pages 53 ff.).

- 1** Remove all packaging materials (refer to Section A, Fig. A).
- 2** Fill the removable tank **9** and wait 30 minutes before you ignite the heater (refer to Section B, Fig. H).
- 3** Insert the batteries into the battery holder **12** (refer to Section A, Fig. F).
- 4** Check whether the combustion chamber **4** is fully upright (refer to Section A, Fig. E).
- 5** Ignite the heater by turning the knurled wick adjustment knob **2** as far to the right as possible and then gently push the ignition button **3** (refer to Section C, Fig. J and K).
- 6** After igniting the heater it will take 10 to 15 minutes before you can check if the heater burns well (refer to Section D).
- 7** Switch off the heater (refer to Section E).

- The first time you ignite your heater it will smell like 'new' for a short time.
- Store your fuel in a cool and dark place.
- Fuel has a limited shelf life. Start every heating season with new fuel.
- The right quality of fuel will be assured, when you use Zibro Extra or Zibro Kristal for your heater.
- If you change to another brand and/or type of paraffin oil, you must first finish up all the remaining fuel in the heater.

MAIN COMPONENTS

- 1** OFF button
- 2** Knurled wick adjustment knob
- 3** Ignition button
- 4** Combustion chamber
- 5** Combustion chamber handle
- 6** Fuel indicator
- 7** Grill
- 8** Lid for removable tank
- 9** Removable tank
- 10** Fuel gauge removable tank
- 11** Ignition coil
- 12** Battery holder
- 13** Wick height lock

WHAT YOU NEED TO KNOW IN ADVANCE

ALWAYS MAKE SURE THAT THERE IS SUFFICIENT VENTILATION

For each model the minimum size of space is specified in which you can use the heater safely, without additional ventilation (*refer to Section K*). If a particular room is smaller than the specified space, always leave a window or door slightly ajar (± 2.5 cm). We also recommend doing this in highly insulated or draught-free rooms and/or at altitudes above 1,500 metres. Do not use your heater in cellars or other underground areas.

SAFE TOP

The heater is supplied with a safe top. This application decreases the temperature of the top plate. In this way, the risk of harmful accidents at accidentally touching the top plate is considerably decreased. However, be aware that the top plate still becomes hot.



Avoid any contact with the top plate and grille.

THE RIGHT FUEL

Only use Class C1 paraffin fuel in accordance with BS2869 Part two, or equivalent. Your heater has been designed for use with high-quality water-free pure paraffin oil, such as Zibro Extra or Zibro Kristal. Only fuels of this kind will ensure clean and proper burning. Lower quality fuel may result in:

- ▶ excessive tar deposits on the glass fibre wick
- ▶ incomplete burning
- ▶ reduced heater lifetime
- ▶ smoke and/or smells
- ▶ deposits on the grid or mantle

Using the right fuel is therefore essential for safe, efficient, and comfortable use of your heater.

Always refer to your local dealer for the right fuel for your heater.



Only the use of the correct fuel will ensure safe, efficient, and comfortable use of your heater.

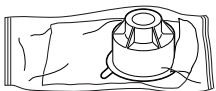

This transportation cap is packed separately in the box. Only this cap ensures trouble-free transportation of the heater after use. Store it well!

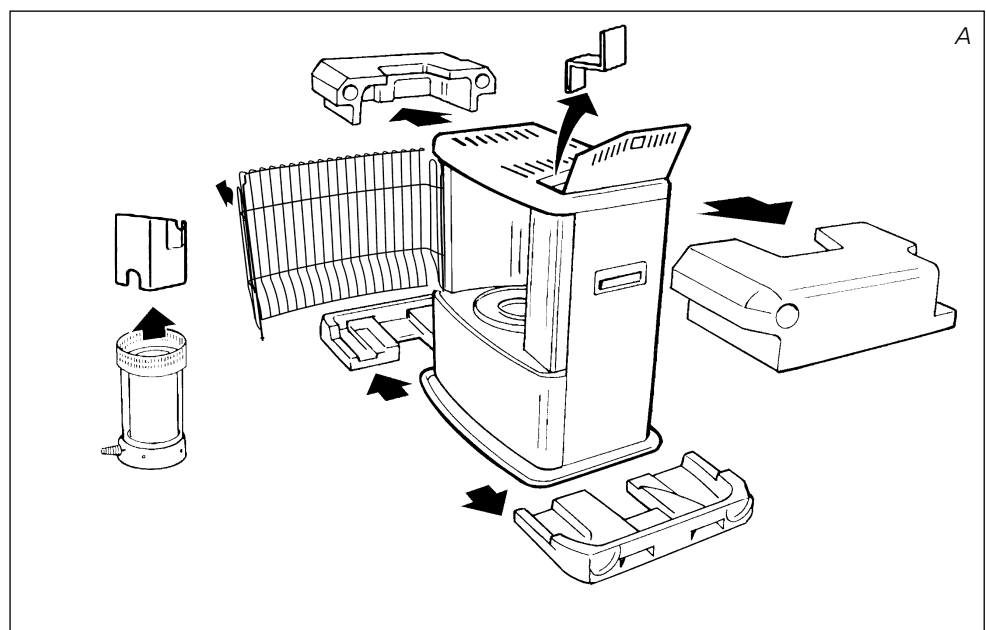

A INSTALLING THE HEATER

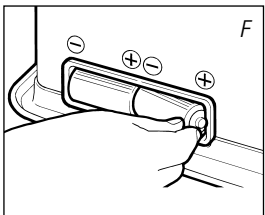
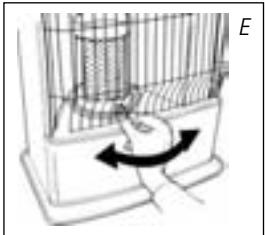
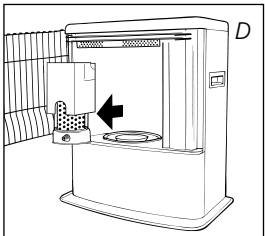
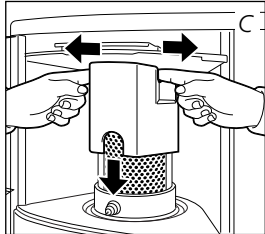
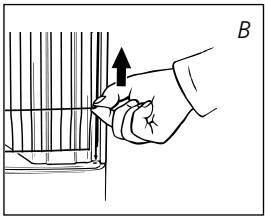

- 1 Carefully remove your heater from the box and check the contents. In addition to the heater you also need to have:

- ▶ a manual fuel pump
- ▶ a transportation cap
- ▶ these directions for use
- ▶ batteries

Keep the box and the packaging materials (Fig. A) for storage and/or transportation.

- 2 Remove the other packaging materials:

- ▶ Remove the packaging material from the grill 7. Lift the grill from the slot (Fig. B) and pull it forward.
- ▶ Pull both ends of the packaging to the rear and at the same time slightly downwards (see Fig. C).
- ▶ Remove the combustion chamber from the heater and remove the packaging underneath (see Fig. D).
- ▶ Put the combustion chamber back into its place. The combustion chamber is positioned correctly when it can be smoothly moved a little to the left and to the right by its handle 5 (Fig. E). Close the grill: Slightly lift it to reposition it in its slot.
- ▶ Open the lid of the removable tank 8 and remove the piece of cardboard.

- 3 Fill the removable tank as indicated in Section B.

- 4 Insert the batteries into their holder 12 at the back of the heater (Fig. F). Ensure that the positive and negative poles match the + and - marks indicated on the battery housing.

- 5 The floor should be firm and completely level. Reposition the heater, when it is not level. Do not correct the situation by placing books or other goods under the heater.

- 6 Your heater is now ready for use.

B FILLING FUEL

Do not fill the removable tank in the living room, but in a more suitable place (there can always be some spillage). Follow the procedure below:

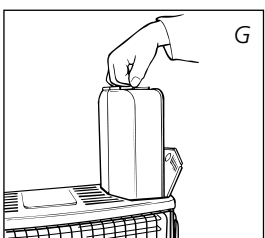

- 1 Make sure that the heater is switched off.

- 2 Open the lid 8 and lift the removable tank 9 out of the heater (Fig. G). Note: Some drops may leak from the tank. Put down the removable tank (cap pointing upwards) and screw off the fuel cap.

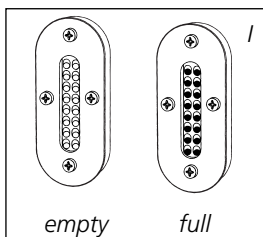
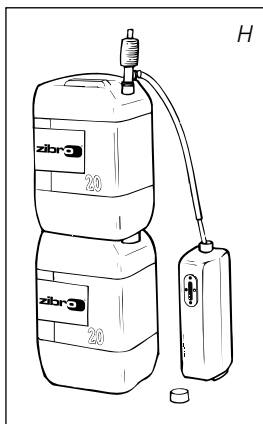

- 3 Take the manual fuel pump and insert the smooth, most rigid tube into the jerrycan. Make sure that it is in a higher position than the removable tank (Fig. H). Insert the ribbed hose into the opening of the removable tank.
- 4 Lock the valve on top of the pump (turn clockwise).
- 5 Squeeze the pump a few times, until fuel starts flowing into the removable tank. As soon as this happens, there is no need to press any longer.
- 6 Check the removable tank fuel gauge ⑩ while filling the tank (Fig. I). Stop filling by loosening the valve on top of the pump (turn anti-clock-wise), once the gauge indicates that the tank is full. Never overfill the tank, especially not when the fuel is very cold (fuel expands when it heats up).
- 7 Let the remaining fuel in the pump flow back into the jerrycan and carefully remove the pump. Carefully screw the fuel cap back on the tank. Clean off any spilled fuel.
- 8 Check whether the fuel cap is straight and tightened properly. Reinstall the removable tank in the heater (cap down). Close the lid.

C IGNITING THE HEATER

A new heater may give off some smells for a short while, when it is used for the first time. You should therefore provide extra ventilation or ignite the heater outside the living room.



When you use the heater for the first time, first put the filled removable tank into place, and then wait approximately 30 minutes before you ignite the heater. This allows the glass fibre wick to soak up the fuel. Follow the same procedure when you have completely burnt up all fuel from the tank, and after the glass fibre wick has been replaced.



Before igniting the heater, always check the fuel indicator ⑥ to see whether the removable tank needs filling up.

Always ignite the heater with the ignition coil ⑪. Never use matches or a cigarette lighter.

Follow the procedure below:

- 1 Turn the knurled wick adjustment knob ② clockwise to its stop (Fig. J). If you apply more pressure you may turn it slightly further; however, it will automatically return to the startposition.
- 2 Push in the ignition button ③ (Fig. K), but do not apply too much force. Release the ignition button as soon as a flame is visible in the combustion chamber ④.

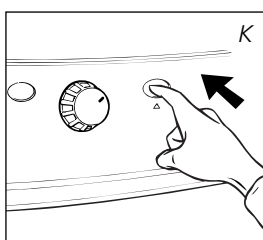
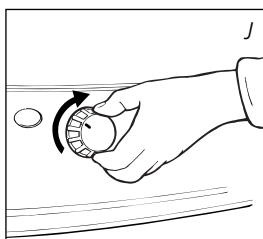

GB



If the heater has been used only a few times and the wick adjustment knob is not locked, first turn the wick adjustment knob (Fig. L) completely left, before putting the wick in the highest position for ignition (Section C).

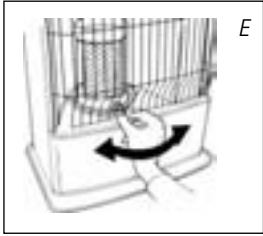

After having ignited the heater, always check whether the combustion chamber ④ is level, by sliding it slightly to the left and the right by its handle ⑤ (Fig. E). This should be a smooth movement. If the combustion chamber is not level, this will cause smoke and soot to develop.

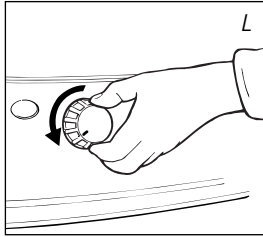

D BURNING OF THE HEATER

After you have ignited the heater, it will take 10 to 15 minutes before you can check whether the heater is burning well. Too high a flame may cause smoke and soot, whereas too low a flame causes smells. The page opposite the folding page shows the minimum and maximum permissible burning heights of the flame (Fig. P). The flame can be slightly adjusted with the knurled wick adjustment knob ② (Fig. L).

Burning that is too low may be caused by:

- ▶ insufficient fuel (fill the tank)
- ▶ poor fuel quality (contact your dealer)
- ▶ insufficient ventilation (put window or door ajar)
- ▶ wastage of the wick (contact your dealer or replace the wick, refer to section M)

E SWITCHING OFF THE HEATER

Let the heater burn at its lowest setting (Fig. L) for approximately one minute. Then slowly turn the knurled wick adjustment knob ② anti-clockwise to its stop. The flame will extinguish after a little while.

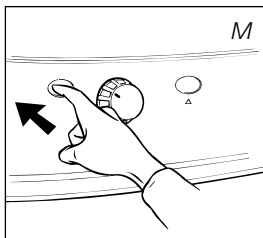

In case of an emergency, switch off the heater by pushing in the OFF button ① (Fig. M).

F ADJUSTING THE WICK HEIGHT

After a period of time the combustion may no longer be high enough (Section D). In that case you can adjust the wick height to improve the flame. To do this, the heater must have been switched off. Follow the procedure below:

- 1 Push the OFF button ① (Fig. M).
- 2 Pull the knurled wick adjustment knob ② off the heater, so the wick height lock ⑬ will be visible.
- 3 Take the plastic collar between your thumb and index finger and pull it out. Turn the collar up one step, to either position 2 or 3 (Fig. Q). Carefully push the collar back, so the pin engages in the recess.
- 4 Carefully reinstall the knurled wick adjustment knob. This can be done in one way only - check the rear of the cap for the correct position.

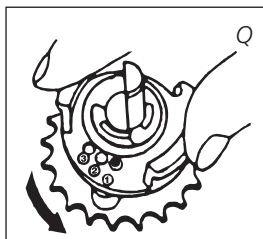

If adjustment of the wick height does not have the required effect, let the heater burn until all fuel has been used up (Section H).

If the flame height is still too low and the wick is set on position 3, then contact your dealer, or replace the wick, refer to section M. If the flame gets too high after adjusting (Fig Q), the wick height lock should be placed one position lower again. Otherwise smoke or soot may be caused.

G MALFUNCTION, CAUSES AND SOLUTIONS

If any malfunctioning cannot be solved from the directions below, please contact your dealer.

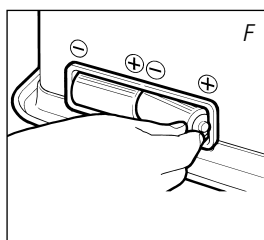

THE HEATER DOES NOT IGNITE

- ▶ The batteries are not positioned correctly in the holder.
Check (Fig. F).
- ▶ There is not enough power left in the batteries for the ignition.
Replace (Fig. F).
- ▶ You have run out of fuel from the tank or the wick has been replaced.
After having refilled and replaced the removable tank, wait for 30 minutes before igniting the heater.
- ▶ You are pushing the ignition button ③ with too much force.
Push it in less forcefully (Section C).
- ▶ The ignition coil ⑪ is defective.
Contact your dealer.

IRREGULAR FLAME AND/OR SOOT AND/OR SMELLS

- ▶ The combustion chamber ④ has not been positioned correctly.
Use the handle ⑤ to put it level, until you can easily slide it slightly to the left and to the right and the chamber is level.
- ▶ You are using fuel which is past its 'use by' date.
Start every heating season with fresh fuel.
- ▶ You are using the incorrect type of fuel.
Refer to THE RIGHT FUEL (See Section 'What you need to know in advance').
- ▶ Dust has gathered in the lower part of the heater.
Contact your dealer.
- ▶ The wick height is not correct.
See section F.

THE HEATER SLOWLY EXTINGUISHES

- ▶ The removable tank is empty.
See Section B.
- ▶ The fuel filter is contaminated by moist.
Dry the fuel filter (Section H).
- ▶ The lower reservoir is contaminated by moist.
Contact your dealer.
- ▶ The wick has hardened on the upper side.
Burn the heater until all fuel is used (Section H). Use the right fuel.
- ▶ You are using fuel which is past its 'use by' date.
Start every heating season with fresh fuel.

THE HEATER REMAINS BURNING LOW

- ▶ Wick position too low.
Reinstall the wick height lock (Section F).
- ▶ Before you refilled the tank, the heater had burnt up almost all the fuel.
After having refilled and replaced the removable tank, wait for 30 minutes before igniting the heater.
- ▶ You are using the incorrect type of fuel.
Refer to THE RIGHT FUEL (See Section 'What you need to know in advance').
- ▶ The room is insufficiently ventilated.
Leave a window or a door wide open for a while.

THE HEATER IS BURNING TOO HIGH

- ▶ You are using an incorrect, too volatile type of fuel.
Refer to THE RIGHT FUEL (See Section 'What you need to know in advance').
- ▶ Wick position too high.
Reinstall the wick height lock (Section F).

H MAINTENANCE

Your heater needs hardly any maintenance. It is, however, important that you remove dust and stains in time with a damp cloth, because otherwise these may cause stains that are hard to remove. Under normal conditions, only three components are subject to wear:



1. THE BATTERIES

You may replace the batteries yourself. Do not dispose of old batteries along with the other domestic waste. Follow the locally applicable regulations regarding the disposal of domestic chemical waste.

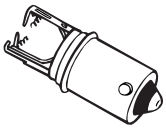

broken ignition coil

2. THE IGNITION COIL

The ignition coil will have a longer life, if you ignite the heater in the correct manner. Replace the batteries in time and take care not to push in the ignition button with too much force. If the filament is broken, the ignition coil must be replaced.

3. THE WICK

To extend the glass fibre wick life, you must occasionally let the heater burn until the tank is completely emptied and the heater extinguishes by itself. Do this when you notice that the flame is weakening. The burn-out will cause some smells, so it is recommended that you take the heater outside of the living room.

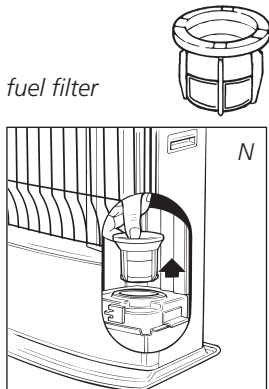

fuel filter

THE FUEL FILTER

Check the fuel filter regularly as well.

Remove the removable tank ⑨ from the heater and take out the fuel filter (Fig. N). Some drops of fuel may spill from the filter; keep a cloth at hand. Turn the fuel filter upside down and clean it from all dirt deposits by tapping it on a hard surface. **(Never clean it with water!)** Reposition the fuel filter in the heater.



Do not remove any heater components yourself. Always contact your dealer for repairs.



Let the heater cool down first, before you start any maintenance or service work.

I STORAGE (END OF THE HEATING SEASON)

We recommend that you burn up all the fuel in the fuel tank at the end of the heating season and store the heater properly. Follow the procedure on the next page:

- 1 Ignite the heater outside the living room and let it burn until all fuel is used.

- 2 Let the heater cool down.
- 3 Clean the heater with a damp cloth and then dry it with a dry cloth.
- 4 Remove the batteries from the holder 12 and store them in a dry place.
- 5 Clean the fuel filter (refer to section H).
- 6 Store the heater in a dust-free place, if possible in its original packaging. Unused fuel cannot be used for the next heating season. If there is still some fuel left, do not throw it away, but dispose of it in accordance with the local regulations for the disposal of domestic chemical waste. Always start the new heating season with fresh fuel. When you start re-using the heater, follow the instructions again (starting from Section A and as specified).

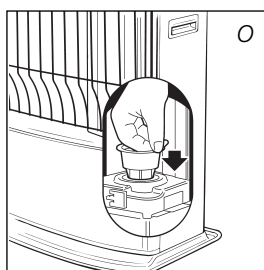
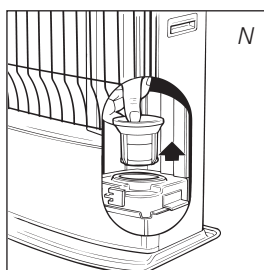

Transportation cap

J TRANSPORTATION

Take the following measures to avoid fuel leakage during the transportation of the heater:

- 1 Let the heater cool down.
- 2 Remove the removable tank 9 from the heater and remove the fuel filter (Fig. N). Some drops may leak from the filter; keep a cloth at hand. Store the fuel filter and the removable tank outside the heater.
- 3 Place the transportation cap into the position of the fuel filter (Fig. O). Press it tight.
- 4 Always move the heater in an upright position.

K SPECIFICATIONS

Ignition	electrical	Dimensions (mm)	width	428
Fuel	paraffin	(including base plate)	depth	295
Capacity (kW)*	3.00		height	513
Suitable space (m ³)**	85-110	Accessories:	manual fuel pump	
Fuel consumption (l/hr)*	0.313		transportation cap	
Fuel consumption (g/hr)*	250		batteries	
Burning time per tank (hr)*	12.8	Required batteries	2x R20kG, MN 1300	
Capacity removable tank (litres)	4.0		1.5V, size D	
Weight (kg)	9.0	Wick type	F	

* At maximum setting

** Specified values are indicative



L WARRANTY PROVISIONS

Your heater comes with a 24-month warranty starting on the date of purchase. Within this period all defects in material or workmanship will be repaired without any charge. The following provisions shall apply regarding this warranty:

- 1 We expressly dismiss all other claims for damages, including consequential damages.
- 2 Any repairs or replacements of components within the term of warranty will not result in an extension of the term of warranty.
- 3 The warranty will no longer apply, when the heater has been modified, non-original parts have been used, or when it is repaired by third parties.
- 4 The warranty will not apply to parts that are subject to normal wear, such as the batteries, the ignition coil, the wick and the manual fuel pump.
- 5 The warranty will only apply, when you present the original, dated proof of purchase, provided no changes have been made to it.
- 6 The warranty will not apply to damages caused by actions not in compliance with the Directions for Use, neglect, and the use of an incorrect type of fuel, or fuel past its use-by date. The use of incorrect fuel can even be dangerous*.
- 7 Transportation costs and the risks involved during the transportation of the heater or heater components will always be the responsibility of the purchaser.

In order to avoid unnecessary costs, we recommend that you always read the 'Directions for Use' carefully first. In case they offer no solution, please take the heater to your dealer for repair.

* Highly inflammable substances may induce uncontrollable burning, causing flames to break out. Should this happen, never try to move the heater, but always switch off the heater immediately (*refer to Section E*). In cases of emergency you may use a fire extinguisher, but only a type B extinguisher: a carbon dioxide or powder extinguisher.

10 TIPS FOR SAFE USE

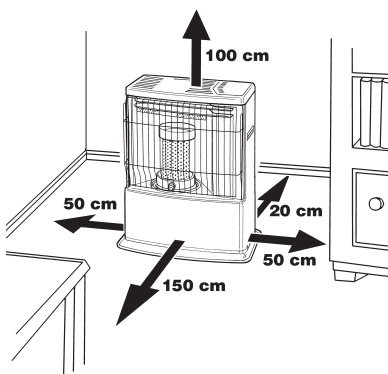

- 1 Make sure that children are always aware of the presence of a burning heater.
- 2 Do not move the heater when it is burning or still hot. Do not refill nor service the heater when it is burning or still hot.
- 3 Position the front of the heater at a minimum distance of 1.5 metres from walls, curtains, and furniture.
- 4 Do not use the heater in dusty rooms or in very draughty places. In both cases you will not have optimum burning.
- 5 Switch off the heater, before you go to sleep.
- 6 Store and move fuel only in suitable tanks and jerrycans.
- 7 Make sure that the fuel is not exposed to heat or extreme temperature changes. Always store the fuel in a cool, dry and dark place (sunlight will affect the quality).
- 8 Never use the heater in places where harmful gasses or fumes may be present (e.g. exhaust gasses or paint fumes).
- 9 Be aware that the grid of the heater becomes hot. If the appliance is covered there is a risk of fire.
- 10 Always make sure that there is sufficient ventilation.

REPLACEMENT OF THE WICK

M ENSURE THAT THE HEATER IS OFF AND COMPLETELY COOL BEFORE STARTING TO REPLACE THE WICK.

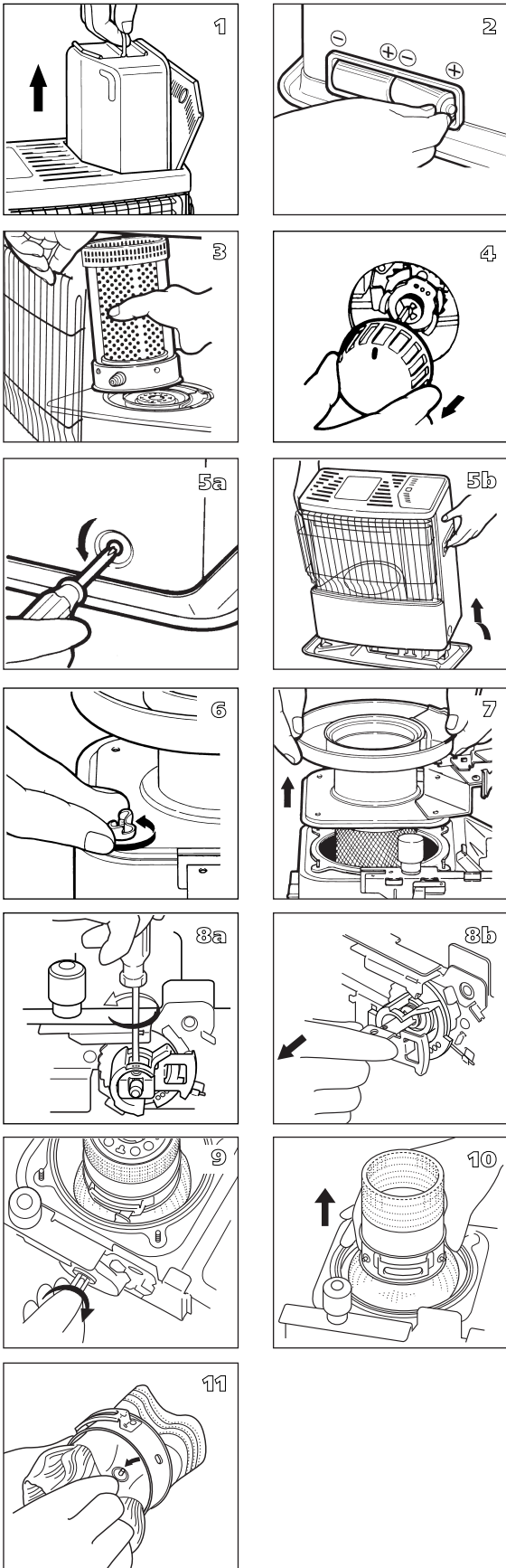

- 1 Open the lid and remove the removable tank.
- 2 Remove the batteries from the battery holder.
- 3 Open the front grill. Remove the combustion chamber from the heater. Close the grill.
- 4 Pull the knurled wick adjustment knob off the heater.
- 5 Unscrew the three cabinet screws on the back and sides of the heater. Pull the cabinet forward slightly, and then remove it from the base plate.
- 6 Unscrew the four wing nuts from the wick holder.
- 7 Lift up the wick holder and the wick mechanism.
- 8 Remove the screw on the stem holding the bracket and remove the bracket, spring and wick height lock.
- 9 Turn right the stem to the end and remove the wick sleeve (with wick).
- 10 Lift the wick sleeve up and remove it from the primary air tube.
- 11 Squeeze the wick to loosen the three wick pins and remove the wick from the wick sleeve. Ensure that you are wearing gloves and that you have a container in which to put the old wick.

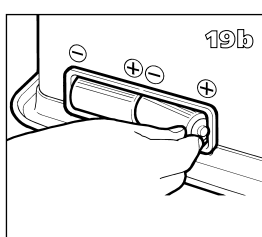
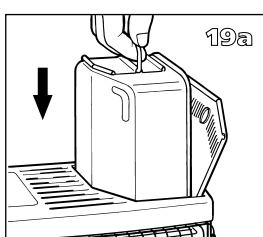
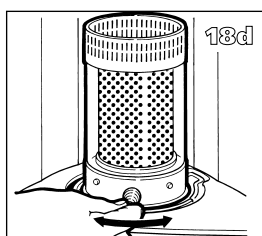
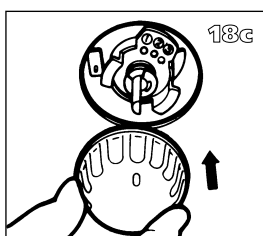
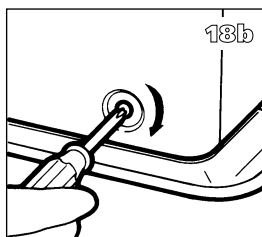
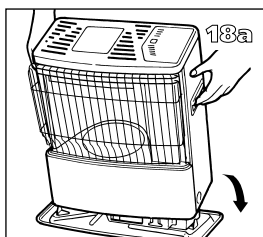
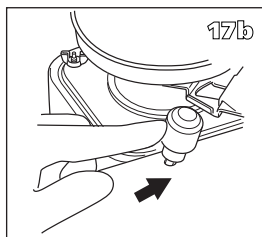
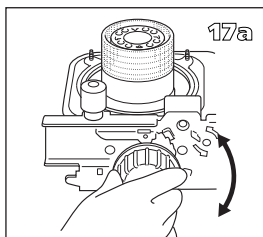
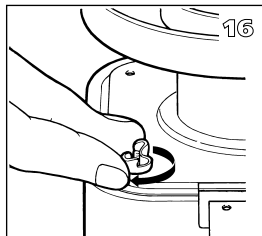
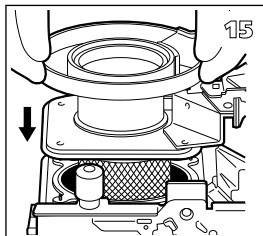
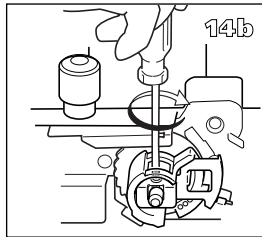
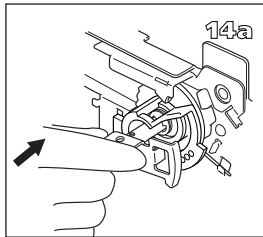
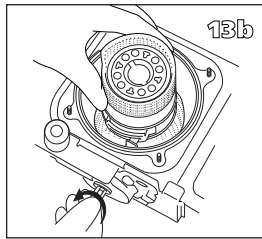
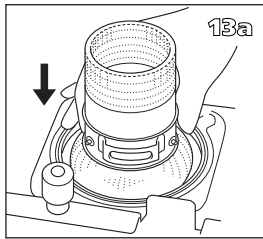
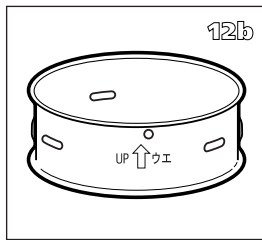
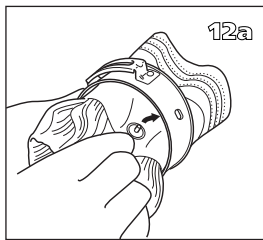

- 12** Install the wick to the wick sleeve according to the allowed direction engraved on the wick sleeve.
- 13** Install the wick sleeve (with wick) to the primary air tube. And then install the top of the stem into the groove of the wick sleeve (with wick) from right side, and left the stem to the end.
- 14** Install the wick height lock (the wick position should be adjusted at No. 1), spring and bracket. Then tighten the screw which is holding the stem.
- 15** Put the wick holder chassis back into position.
- 16** Screw the four wing nuts hand tight.
- 17** Place the knurled wick adjustment knob on the wick mechanism. Turn the knob as far to the right as possible. Press the tip-over switch. Check that the wick can be lowered completely. Repeat this check a number of times. If the wick cannot be lowered completely it has not been placed correctly. If this is the case, repeat the procedure from No. 12. Pull the knurled wick adjustment knob off the heater.
- 18** Put the cabinet back into position and tighten the three screws. Put the knurled wick adjustment knob back into position. Now put the combustion chamber back into position. Check that it is level by sliding it slightly to the left and the right by its handle. Close the grill.
- 19** Put the filled removable tank into position. Put the batteries into the battery holder (ensure that the positive and negative poles match the + and - marks indicated on the battery housing). Wait 30 minutes after replacing the tank and batteries before using the heater.

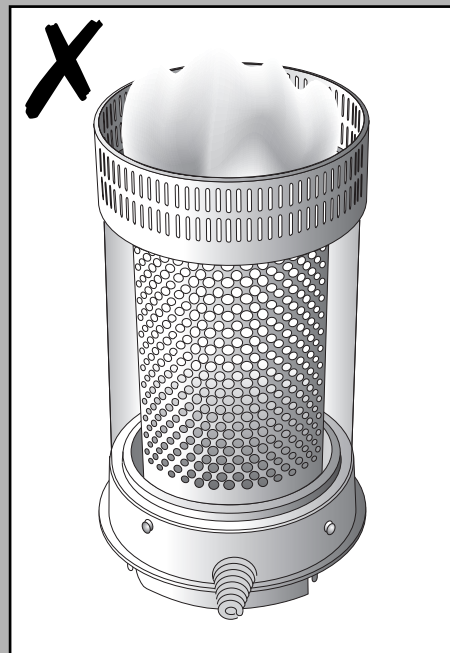
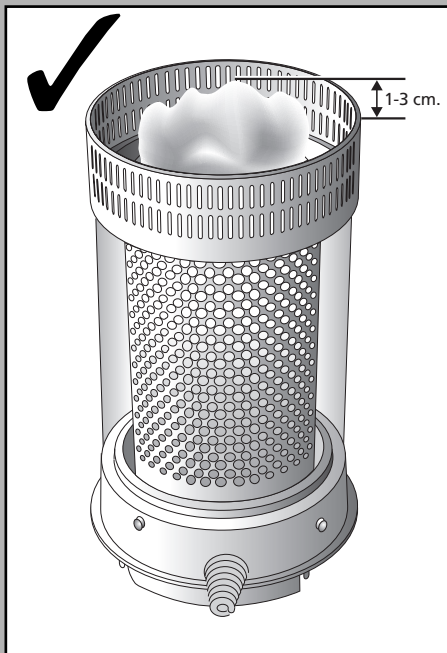
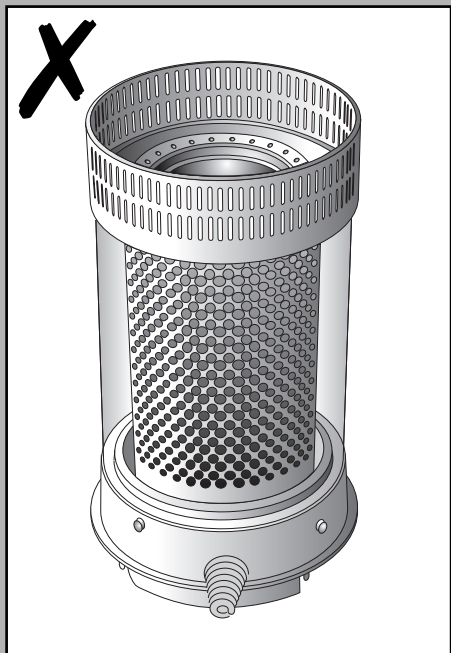

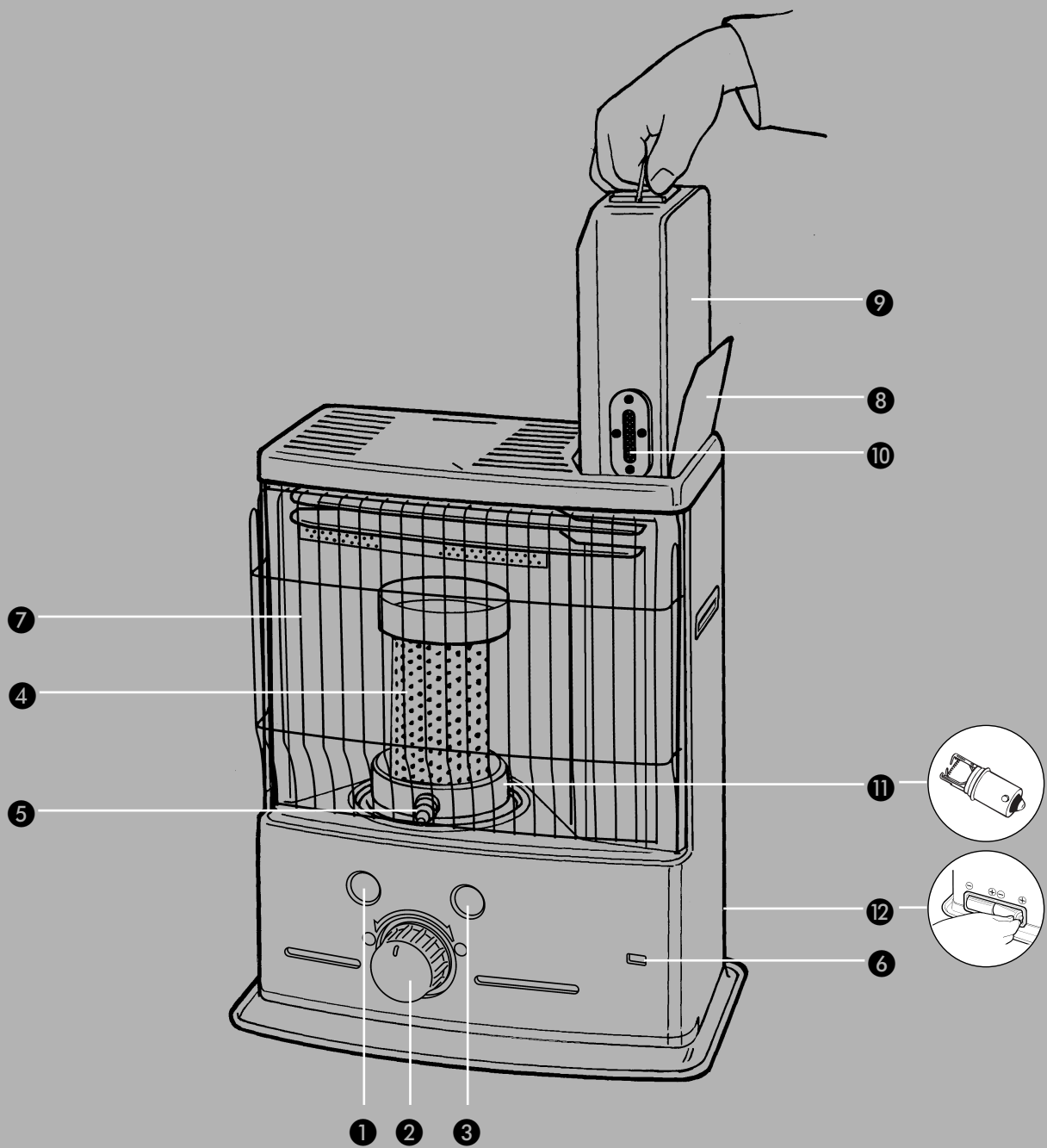

DISTRIBUTED IN EUROPE BY PVG INTERNATIONAL b.v.

A ÖSTERREICH

PVG Austria VertriebsgmbH
Salaberg 49
3350 HAAG
tel: +43 7434 44867
fax: +43 7434 44868
email: pvgaustria@zibro.com

B BELGIË

PVG Belgium NV/SA
Industrielaan 55
2900 SCHOTEN
tel: +32 3 326 39 39
fax: +32 3 326 26 39
email: pvgbelgium@zibro.com

CH SCHWEIZ

PVG Schweiz AG
Salinenstrasse 63
4133 PRATTELN
tel: +41 61 337 26 51
fax: +41 61 337 26 78
email: pvgint@zibro.com

D DEUTSCHLAND

PVG Deutschland GmbH
Siemensstrasse 31
47533 KLEVE
tel: 0800 - 9427646
fax: +31 (0)412 648 385
email: pvgdeutschland@zibro.com

DK DANMARK

Appliance A/S
Blavstrod Teglvaerksvej 3
DK-3450 ALLEROED
tel: +45 70 205 701
fax: +45 70 208 701
email: appliance@appliance-group.com

E ESPAÑA

PVG España S.A.
Pol. Ind. San José de Valderas II
Comunidad "La Alameda"
C/ Aurora Boreal, 19
28918 LEGANÉS (Madrid)
tel: +34 91 611 31 13
fax: +34 91 612 73 04
email: pvgspain@zibro.com

F FRANCE

PVG France SARL
4, Rue Jean Sibélius
B.P. 185
76410 SOTTEVILLE SOUS LE VAL
tel: +33 2 32 96 07 47
fax: +33 0 820 34 64 84
email: pvgfrance@zibro.com

FIN SUOMI

Appliance Finland Oy
Piispantilankuja 6C
02240 ESPOO
tel: +358 9 4390 030
fax: +358 9 4390 0320
email: appliance@appliance-group.com

GB UNITED KINGDOM

Scott Brothers Ltd.
The Old Barn, Holly House Estate
Crnage, Middlewich, CW10 9LT UK
tel.: +44 1606 837787
fax: +44 1606 837757
email: sales@scottmail.co.uk

I ITALIA

PVG Italy SRL
Via Niccolò Copernico 5
50051 CASTELFIORENTINO (FI)
tel: +39 571 628 500
fax: +39 571 628 504
email: pvgitaly@zibro.com

N NORGE

Appliance Norge AS
Vogellunden 31
1394 NESBRU
tel: +47 667 76 200
fax: +47 667 76 201
email: appliance@appliance-group.com

NL NEDERLAND

PVG International B.V.
P.O. Box 96
5340 AB OSS
tel: +31 412 694 694
fax: +31 412 622 893
email: pvgnl@zibro.com

P PORTUGAL

Gardena, Lda
Recta da Granja do Marquês
ALGUEIRÃO
2725-596 MEM MARTINS
tel: + 35 21 92 28 530
fax: + 35 21 92 28 536
email: pvgint@zibro.com

PL POLSKA

PVG Polska Sp. z. o. o.
ul. Kościelna 110
26-800 Białobrzegi
tel: +48 48 613 00 70
fax: +48 48 613 00 70
email: pvgpoland@zibro.com

S SVERIGE

Appliance Sweden AB
Sjögatan 6
25225 HELSINGBORG
tel: +46 42 287 830
fax: +46 42 145 890
email: appliance@appliance-group.com

TR TURKEY

PVG Isıtma Klima Soğutma Ltd.Şti.
Atatürk Cad. No 380 Ak İşhani Kat 6
35220 Alsancak
IZMIR - TURKEY
tel: + 90 232 463 33 72
fax: + 90 232 463 69 91
email: pvgturkey@zibro.com